

UNIFORM STATUTORY DECLARATION FORM FOR THE REGISTRATION OF FITTING DESIGNS

NEW BRUNSWICK
NUNAVUT

NOVA SCOTIA
YUKON

PRINCE EDWARD ISLAND
NORTHWEST TERRITORIES

NEWFOUNDLAND AND LABRADOR

MANUFACTURERS NAME: <u>Swagelok Company</u>	
MANUFACTURERS ADDRESS: <u>29500 Solon Road, Solon, Ohio 44139-3492</u>	
PLANT LOCATIONS: <u>Headquarters: 29500 Solon Road, Solon, Ohio 44139-3492 (See Attachment A)</u>	
<p align="center">CATEGORY OF FITTINGS TO BE REGISTERED. CIRCLE ONE CATEGORY ONLY</p> <p>A Pipe fittings, including couplings, tees, elbows, Ys, plugs, unions, pipe caps, or reducers</p> <p>B Flanges: all flanges</p> <p>C Valves: all line valves</p> <p>D Expansion joints, flexible connections, and hose assemblies: all types</p> <p>E Strainers, filters, separators, and steam traps</p> <p>F Measuring devices, including pressure gauges, level gauges, sight glasses, levels, or pressure transmitters</p> <p>G Certified capacity-rated pressure relief devices acceptable as primary over pressure protection on boilers, pressure vessels, piping and fusible plugs</p> <p>H Pressure retaining components that do not fall into one of the above categories</p> <p>N Nuclear components: Class 1 <input type="checkbox"/> Class 2 <input type="checkbox"/> Class 3 <input type="checkbox"/>, (Meeting AECB or ASME requirements)</p>	<p align="center">TITLE OF THE STANDARD OF CONSTRUCTION</p> <p align="center">British Standards Institution</p>
<p>SHOW MANUFACTURERS NAME, TRADEMARK, OR LOGO AS IT WILL APPEAR ON THE PRODUCT</p> <p align="center" style="font-size: 2em;">Swagelok</p>	<p align="center">TYPE OF CONSTRUCTION</p> <p>FORGED <input type="checkbox"/> WELDED <input type="checkbox"/> WROUGHT <input checked="" type="checkbox"/> CAST <input type="checkbox"/> OTHER <input type="checkbox"/> DESCRIBE OTHER:</p>
<p>LIST OF SUPPORTING DOCUMENTATION AND IDENTIFICATION OF THE ACTUAL ITEMS TO BE REGISTERED:</p> <p>ISO 9001:2008 Quality System Certificate, Support Documents, Attachment B, Catalog Information, Attachment A</p>	

DECLARATION:

I, David H. Peace (see note 3) employed by Swagelok Company and being the person having full authority and responsibility for the quality of the end product do solemnly declare that the information contained in this form is true and to the best of my knowledge represents the product for which registration is sought. The dimensions, materials of construction, pressure temperature ratings, and identification markings are in accordance with the herein named standards. I further declare that the manufacture of these fittings is regulated by a Quality Control Program which extends to each plant where fabrication occurs in whole or in part and has been verified by The British Standards Institution as being suitable for that purpose and I make this solemn declaration conscientiously believing it to be true, and knowing that it is of the same force and effect as if made under oath.

Signature of Declarer: [Signature]

Declared before me at Solon, Ohio

This 01st day of April, AD 2015

Commissioner of Oaths
or Notary Public: (sign) [Signature]

USE THIS SPACE FOR THE
OFFICIAL SEAL

Jamlo L. Ristau
Resident Portage County
Notary Public, State of Ohio
My Commission Expires: 03/08/2019

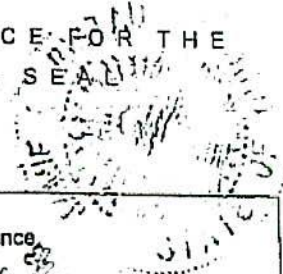

This space for Regulatory Authority use This registration must be revalidated after ten (10) years from the date of acceptance.	
CRN: <u>OC18924.5</u> FID#: <u>1214</u>	Newfoundland Labrador Service NL Registered <u>OC18924.50</u> Date <u>17/02/03</u> Engineering and Inspection Services Registered by <u>[Signature]</u>
<p>Notes:</p> <ol style="list-style-type: none"> All fittings shall be registered in the name of the Manufacturer. Each category shall be supported with two Statutory Declaration forms and one copy of supporting documentation. The declaration shall be made by the person having full authority and responsibility for the quality of the end product. Quality control programs shall be resubmitted for validation at a maximum interval of five (5) years. 	
UNDER THE AUTHORITY OF THE PUBLIC SAFETY ACT AND THE BOILER, PRESSURE VESSEL AND COMPRESSED GAS REGULATION	

Attachment B1. Scope for Swagelok Special Alloy 60 Series Ball Valves (Category C)

This document represents the scope of the Swagelok Special Alloy 60 Series Ball Valves covered by this submission for CRN approval. The Swagelok Special Alloy 60 Series Valves were designed and evaluated in accordance with ASME B31.1 for unlisted components and ASME B31.3 for unlisted components.

Summary Table

Product Description or Series	Main Pressure Bearing Component	Main Pressure Bearing Material (Standard)	Port Connections and Sizes	Maximum Rated Pressure		Design Code of Construction
				At ambient temperature	At maximum temperature	
63	Body	Stainless Steel 6MO (ASTM A276 UNS S31254)	Swagelok Tube Fitting 1/2" Female NPT 1/2"	2,200 psi @ 100 °F	100 psi @ 450 °F	ASME B31.1 (Unlisted Components) and ASME B31.3 (Unlisted Components)
		Stainless Steel 2507 (ASTM A479 UNS S32750)	Swagelok Tube Fitting 1/2" Female NPT 1/2"	2,200 psi @ 100 °F	100 psi @ 450 °F	ASME B31.1 (Unlisted Components) and ASME B31.3 (Unlisted Components)
		Alloy 825 (ASTM B425 UNS N08825)	Swagelok Tube Fitting 1/2" Female NPT 1/2"	2,200 psi @ 100 °F	100 psi @ 450 °F	ASME B31.1 (Unlisted Components) and ASME B31.3 (Unlisted Components)
		Alloy 625 (ASTM B446 UNS N06625)	Swagelok Tube Fitting 1/2" Female NPT 1/2"	2,200 psi @ 100 °F	100 psi @ 450 °F	ASME B31.1 (Unlisted Components) and ASME B31.3 (Unlisted Components)

For more information about pressure ratings of valves with tube fitting end connections, see Swagelok Tubing Data, MS-01-107.

Product Illustrations



Product Options:

The product options listed below affect pressure and/or temperature ratings shown in the above Summary Table, but in all cases the ratings are less than those shown in the table.

Flange Seal Material Options

Fluorocarbon, FKM
Buna N
Buna C
Ethylene Propylene
Neoprene
Grafoil
PTFE

Stem Seal Material Options

PTFE, virgin
Fluorocarbon, FKM
Buna C
Ethylene Propylene
Grafoil

Seat Material Options

PTFE, virgin
PTFE, reinforced
PTFE, carbon glass filled
PEEK
UHMWPE

Additional options and non-pressure boundary alterations that do not affect pressure-temperature ratings may be made available within the scope of this registration. Examples of these would include the following:

Handle options
Actuators (e.g. pneumatic, electric)
Panel mounting
Low dead space inserts

All of the above options, those that affect pressure and/or temperature ratings and those that do not, are within the scope of this approval.

Quality System

The Swagelok Company quality system complies with the requirements of BS EN ISO 9001:2008. The Swagelok Company maintains British Standards Institution Certificate of Registration Number FM 01729, which applies to all locations listed on the Certificate. The Special Alloy 60 Series Ball Valves products are made at a Swagelok Company location in Solon, Ohio.

References

The product catalog does not represent the full scope of registration, but rather details some of the most common options.

- 60 Series Ball Valves – Special-Alloy Fluid System Components Catalog MS-02-439

Attachment B2. Scope for Swagelok Special Alloy 83 Series Ball Valves (Category C)

This document represents the scope of the Swagelok Special Alloy 83 Series Ball Valves covered by this submission for CRN approval. The Swagelok Special Alloy 83 Series Ball Valves were designed and evaluated in accordance with ASME B31.1 for unlisted components and ASME B31.3 for unlisted components.

Summary Table

Product Description or Series	Main Pressure Bearing Component	Main Pressure Bearing Material (Standard)	Port Connections and Sizes	Maximum Rated Pressure		Design Code of Construction
				At ambient temperature	At maximum temperature	
83	Body	Stainless Steel 2507 (ASTM A479 UNS S32750)	Swagelok Tube Fitting 1/4", 3/8", 1/2", 6MM, 8MM, 10MM, 12MM Female NPT 1/8", 1/4", 1/2"	6,000 psi @ 100 °F	500 psi @ 450 °F	ASME B31.1 (Unlisted Components) and ASME B31.3 (Unlisted Components)
		Alloy 825 (ASTM B425 UNS N08825)	Swagelok Tube Fitting 1/4", 3/8", 1/2", 6MM, 8MM, 10MM, 12MM Female NPT 1/8", 1/4", 1/2"	6,000 psi @ 100 °F	500 psi @ 450 °F	ASME B31.1 (Unlisted Components) and ASME B31.3 (Unlisted Components)

For more information about pressure ratings of valves with tube fitting end connections, see Swagelok Tubing Data, MS-01-107.

Product Illustrations



Product Options

Additional options that do not affect pressure-temperature ratings may be made available within the scope of this registration. Examples of these would include 3-way valves, seat materials, stem seal materials, actuators.

Quality System

The Swagelok Company quality system complies with the requirements of BS EN ISO 9001:2008. The Swagelok Company maintains British Standards Institution Certificate of Registration Number FM 01729, which applies to all locations listed on the Certificate. Special Alloy 83 Series Ball Valves products are made at a Swagelok Company location in Solon, Ohio.

References

The product catalog does not represent the full scope of registration, but rather details some of the most common options.

- 83 Series Ball Valves – Special-Alloy Fluid System Components Catalog MS-02-357

Attachment B3. Scope for Swagelok Special Alloy Bleed Valves (Category C)

This document represents the scope of the Swagelok Special Alloy Bleed Valves covered by this submission for CRN approval. The Swagelok Special Alloy Bleed Valves were designed and evaluated in accordance with ASME B31.1 for unlisted components and ASME B31.3 for unlisted components.

Summary Table

Product Description or Series	Main Pressure Bearing Component	Main Pressure Bearing Material (Standard)	Port Connections and Sizes	Maximum Rated Pressure		Design Code of Construction
				At ambient temperature	At maximum temperature	
BV	Body	Stainless Steel 2507 (ASTM A479 UNS S32750)	Male NPT 1/4", 3/8", 1/2"	10,000 psi @ 100 °F	8,965 psi @ 482 °F	ASME B31.1 (Unlisted Components) and ASME B31.3 (Unlisted Components)
		Alloy 625 (ASTM B446 UNS N06625)	Male NPT 1/4", 3/8", 1/2"	10,000 psi @ 100 °F	7,490 psi @ 850 °F	ASME B31.1 (Unlisted Components) and ASME B31.3 (Unlisted Components)
		Alloy 825 (ASTM B425 UNS N08825)	Male NPT 1/4", 3/8", 1/2"	10,000 psi @ 100 °F	7,295 psi @ 850 °F (Note 1)	ASME B31.1 (Unlisted Components) and ASME B31.3 (Unlisted Components)
		Hastelloy C (ASTM B574 UNS N10276)	Male NPT 1/4", 3/8", 1/2"	10,000 psi @ 100 °F	6,155 psi @ 850 °F	ASME B31.1 (Unlisted Components) and ASME B31.3 (Unlisted Components)

Notes:

(1) For ASME B31.1 applications, this product is rated to 7,295 psi @ 800°F.

Product Illustrations



Typical Product Characteristics:

Some of the product options listed below affect the pressure-temperature ratings shown in the Summary Table, but in all cases the ratings are less than those shown in the Summary Table. All of the following options are within the scope of this registration:

Typical Options

Handles
Vent Tubes

Additional options and non-pressure boundary alterations that do not affect pressure-temperature ratings may be made available within the scope of this registration. Examples of these would include handle options, actuator options, etc.

Quality System

The Swagelok Company quality system complies with the requirements of BS EN ISO 9001:2008. The Swagelok Company maintains British Standards Institution Certificate of Registration Number FM 01729, which applies to all locations listed on the Certificate. The Special Alloy Bleed Valves products are made at a Swagelok Company location in Solon, Ohio.

References

The product catalog does not represent the full scope of registration, but rather details some of the most common options.

- BV Bleed Valves - Special Alloy Materials Catalog MS-02-356

Attachment B4. Scope for Swagelok Special Alloy CH Series Check Valves (Category C)

This document represents the scope of the Swagelok Special Alloy CH Series Check Valves covered by this submission for CRN approval. The Swagelok Special Alloy Check Valves were designed and evaluated in accordance with ASME B31.1 for unlisted components and ASME B31.3 for unlisted components.

Summary Table

Product Description or Series	Main Pressure Bearing Component	Main Pressure Bearing Material (Standard)	Port Connections and Sizes	Maximum Rated Pressure		Design Code of Construction
				At ambient temperature	At maximum temperature	
CH	Body	Alloy 625 (ASTM B446 UNS N06625)	Swagelok Tube Fitting 1/4", 3/8", 1/2" Female NPT 1/4", 3/8", 1/2" Male NPT 1/4", 3/8", 1/2"	6,000 psi @ 100 °F	5070 psi @ 400 °F	ASME B31.1 (Unlisted Components) and ASME B31.3 (Unlisted Components)
		Alloy 825 (ASTM B425 UNS N08825)	Swagelok Tube Fitting 1/4", 3/8", 1/2" Female NPT 1/4", 3/8", 1/2" Male NPT 1/4", 3/8", 1/2"	6,000 psi ① @ 100 °F	4995 psi @ 400 °F	ASME B31.1 (Unlisted Components) and ASME B31.3 (Unlisted Components)
		Stainless Steel 2507 (ASTM A479 UNS S32750)	Swagelok Tube Fitting 1/4", 3/8", 1/2" Female NPT 1/4", 3/8", 1/2" Male NPT 1/4", 3/8", 1/2"	6,000 psi @ 100 °F	5455 psi @ 400 °F	ASME B31.1 (Unlisted Components) and ASME B31.3 (Unlisted Components)

For more information about pressure ratings of valves with tube fitting end connections, see Swagelok Tubing Data, MS-01-107.

①Pressure ratings for valves with 1/2 in. female NPT end connections limited to 5700 psig (392 bar).

Product Illustrations

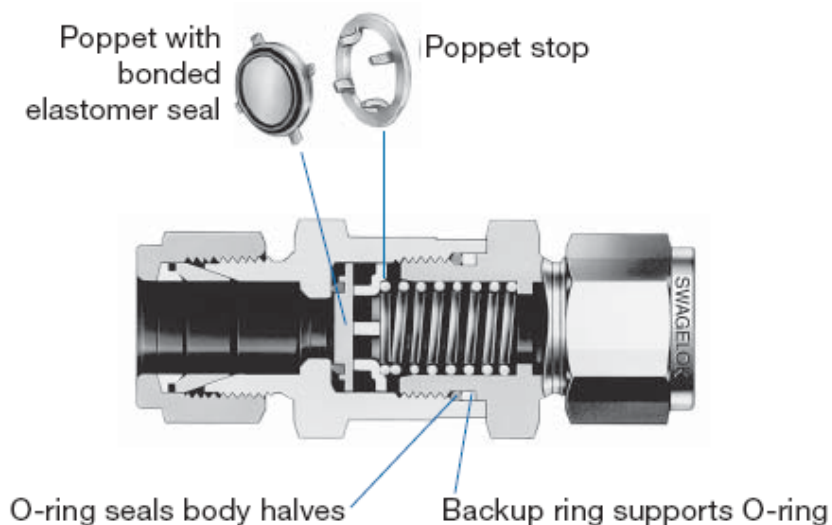

Product Options:

Additional options that do not affect pressure-temperature ratings may be made available within the scope of this registration. Examples of these would include poppet springs and body seal materials.

Quality System

The Swagelok Company quality system complies with the requirements of BS EN ISO 9001:2008. The Swagelok Company maintains British Standards Institution Certificate of Registration Number FM 01729, which applies to all locations listed on the Certificate. The Special Alloy Bleed Valves products are made at a Swagelok Company location in Solon, Ohio.

References

The product catalog does not represent the full scope of registration, but rather details some of the most common options.

- Check Valves – Special Alloy Materials – CH Series Catalog MS-02-440

Attachment B5. Scope for Swagelok Special Alloy N and HN Series Needle Valves (Category C)

This document represents the scope of the Swagelok Special Alloy N and HN Needle Valves covered by this submission for CRN approval. The Swagelok Special Alloy N and HN Needle Valves were designed and evaluated in accordance with ASME B31.1 for unlisted components and ASME B31.3 for unlisted components.

Summary Table

Product Description or Series	Main Pressure Bearing Component	Main Pressure Bearing Material (Standard)	Port Connections and Sizes	Maximum Rated Pressure		Design Code of Construction
				At ambient temperature	At maximum temperature	
3N	Body	Stainless Steel 2507 (ASTM A479 UNS S32750)	Female NPT 1/8", 1/4" Male NPT 1/4" Swagelok Tube Fitting 1/4", 6MM	6,000 psi @ 100 °F	5,370 psi @ 482 °F	ASME B31.1 (Unlisted Components) ASME B31.3 (Unlisted Components)
		Alloy 825 (ASTM B425 UNS N08825)	Female NPT 1/8", 1/4" Male NPT 1/4" Swagelok Tube Fitting 1/4", 6MM	6,000 psi @ 100 °F	4,250 psi @ 1000 °F (Note 1)	ASME B31.1 (Unlisted Components) ASME B31.3 (Unlisted Components)
6N	Body	Alloy 825 (ASTM B425 UNS N08825)	Female NPT 1/4", 3/8" Swagelok Tube Fitting 3/8", 1/2", 10MM, 12MM	6,000 psi @ 100 °F	4,250 psi @ 1000 °F (Note 1)	ASME B31.1 (Unlisted Components) ASME B31.3 (Unlisted Components)
		Stainless Steel 6MO (ASTM A182 UNS S31254)	Female NPT 1/4", 3/8" Swagelok Tube Fitting 3/8", 1/2", 10MM, 12MM	6,000 psi @ 100 °F	3,860 psi @ 750 °F	ASME B31.1 (Unlisted Components) ASME B31.3 (Unlisted Components)
12N	Body	Alloy 825 (ASTM B425 UNS N08825)	Female NPT 1/2", 3/4", 1" Male NPT 1/2", 3/4", 1" Swagelok Tube Fitting 1/2", 3/4", 12MM	6,000 psi @ 100 °F	4,250 psi @ 1000 °F (Note 1)	ASME B31.1 (Unlisted Components) ASME B31.3 (Unlisted Components)
		Stainless Steel 6MO (ASTM A182 UNS S31254)	Female NPT 1/2", 3/4", 1" Male NPT 1/2", 3/4", 1" Swagelok Tube Fitting 1/2", 3/4", 12MM	6,000 psi @ 100 °F	3,860 psi @ 750 °F	ASME B31.1 (Unlisted Components) ASME B31.3 (Unlisted Components)

Notes:

(1) For ASME B31.1 applications, this product is rated to 4,380 psi @ 800°F.

For more information about pressure ratings of valves with tube fitting end connections, see Swagelok® Tubing Data, MS-01-107.

Product Description or Series	Main Pressure Bearing Component	Main Pressure Bearing Material (Standard)	Port Connections and Sizes	Maximum Rated Pressure		Design Code of Construction
				At ambient temperature	At maximum temperature	
3HN	Body	Stainless Steel 2507 (ASTM A479 UNS S32750)	Female NPT 1/8", 1/4" Male NPT 1/4" Swagelok Tube Fitting 1/4", 6MM	10,000 psi @ 100 °F	8,960 psi @ 482 °F	ASME B31.1 (Unlisted Components) ASME B31.3 (Unlisted Components)
		Alloy 825 (ASTM B425 UNS N08825)	Female NPT 1/8", 1/4" Male NPT 1/4" Swagelok Tube Fitting 1/4", 6MM	10,000 psi @ 100 °F	7,080 psi @ 1000 °F (Note 1)	ASME B31.1 (Unlisted Components) ASME B31.3 (Unlisted Components)
6HN	Body	Stainless Steel 2507 (ASTM A479 UNS S32750)	Female NPT 1/4", 1/2" Male NPT 1/2" Swagelok Tube Fitting 3/8", 1/2"	10,000 psi @ 100 °F	8,960 psi @ 482 °F	ASME B31.1 (Unlisted Components) ASME B31.3 (Unlisted Components)

Notes:

(1) For ASME B31.1 applications, this product is rated to 7,295 psi @ 800°F.

For more information about pressure ratings of valves with tube fitting end connections, see Swagelok® Tubing Data, MS-01-107.

Product Illustrations



Typical Product Characteristics

Some of the product options listed below affect the pressure-temperature ratings shown in the Summary Table, but in all cases the ratings are less than those shown. All of the following options are within the scope of this registration:

Typical Options

Handles
Vent Tubes

Additional options and non-pressure boundary alterations that do not affect pressure-temperature ratings may be made available within the scope of this registration. Examples of these would include handle options, actuator options, etc.

Product Options

Additional options that do not affect pressure-temperature ratings may be made available within the scope of this registration. Examples of these would include stem packing seal materials, stem tip, and handle options.

Quality System

The Swagelok Company quality system complies with the requirements of BS EN ISO 9001:2008. The Swagelok Company maintains British Standards Institution Certificate of Registration Number FM 01729, which applies to all locations listed on the Certificate. Special Alloy N and HN Needle Valve products are made at a Swagelok Company location in Solon, Ohio.

References

The product catalog does not represent the full scope of registration, but rather details some of the most common options.

- N, HN Bleed Valves - Special Alloy Materials Catalog MS-02-365